



KAWERAU DISTRICT COUNCIL

Water Supply Bylaw 2009

Kawerau District Council

Water Supply Bylaw 2009

Explanatory Statement

The Local Government Act 2002 defines Council's responsibilities in regard to water supply and its role as a distributor of potable water for domestic, commercial, industrial and fire-fighting purposes.

The Bylaw defines the responsibilities of various classes of consumer. It monitors the operations of the water supply system and outlines procedures to ensure the system is adequately protected from damage and contamination while at the same time providing conservation measures.

The Bylaw covers those functions for which Council may prescribe fees and charges for the supply of water and associated services.

It also covers those functions which relate to supply continuity, connections and disconnections, fittings and materials, prevention of contamination and wastage of water to ensure the continued operation and management of water supply reticulation appropriate to the needs of the Kawerau District.

The Bylaw is made under the powers granted to territorial authorities by Part 8 of the Local Government Act 2002.

Footnote: The primary water supply source for the Kawerau District is a spring located in the Whakatane District which the Kawerau District Council has secured by way of freehold tenure over an allotment containing this source.

Contents

	Page No.	
1	Title	1
2	Commencement	1
3	Repeal	1
4	Application of Bylaw	1
5	Scope	1
6	Interpretation	2
7	Definitions	2
8	Protection of water supply	4
8.1	Water supply system	4
8.2	Protection of source water	5
9	Conditions of supply	5
9.1	Application for supply	5
9.2	Point of supply	6
9.3	Access to and about point of supply	11
9.4	Types of supply	12
9.5	Metering	13
9.6	Level of service	14
9.7	Continuity of supply	14
9.8	Liability	15
9.9	Fire protection connection	15
9.10	Backflow prevention	16
9.11	WSA equipment and inspection	17
9.12	Meters and flow restrictors	17
9.13	Plumbing system	19
9.14	Prevention of waste	19
9.15	Payment	20
9.16	Transfer of rights and responsibilities	20
9.17	Change of ownership	20
9.18	Disconnection at the customer's request	20
10	Offences and Breaches	20
10.1	Breaches of conditions of supply	20
10.2	Interference with equipment	21
10.3	Penalties	22
Table		
1	Compatibility features	19
Figures		
1	Point of supply location – Individual customers	7
2	Typical layout at point of supply	9

Kawerau District Council

Water Supply Bylaw 2009

1 Title

A Bylaw of the Kawerau District Council by way of Special Order pursuant to the provisions of the Local Government Act 2002 and all other Acts, powers and authorities enabling it in that behalf to make a Bylaw to be known as the Kawerau District Council Water Supply Bylaw 2009.

2 Commencement

This Bylaw shall come into force on the 1st day of June 2009.

3 Repeal

As from the day this Bylaw comes into force, any previous bylaw or parts of any bylaw and their amendments in force in the Kawerau District shall be repealed.

4 Application of Bylaw

This Bylaw shall apply to the Kawerau District Council.

5 Scope

This Bylaw is made under the authority of the Local Government Act 2002 for the supply of water to its customers by the Water Supply Authority (WSA). The supply and sale of water by the WSA is subject to:

a) Statutory Acts and Regulations

- i) Building Act 2004
- ii) Fire Service Act 1975
- iii) Health Act 1956
- iv) Local Government Act 2002
- v) Local Government (Rating) Act 2002
- vi) Resource Management Act 1991; and

b) Relevant Codes and Standards

- i) Drinking Water Standards for New Zealand 2005
- ii) BS EN 14154-3:2005 Water meters. Test methods and equipment.
- iii) SNZ PAS 4509:2008 New Zealand Fire Service Fire Fighting Water Supplies Code of Practice.
- iv) NZWWA Backflow Code of Practice 2006
- v) NZWWA Water Meter Code of Practice 2003

6 Interpretation

When interpreting this Bylaw use the definitions set out in section 7 unless the context requires otherwise. If you see a reference to a repealed enactment read that as a reference to its replacement. For the purpose of this Bylaw, the word 'shall' refers to practices that are mandatory for compliance with this Bylaw, while the word 'should' refers to practices that are advised or recommended.

7 Definitions

For the purpose of this Bylaw, unless inconsistent with the context, the following definitions apply:

Approved	Approved in writing by the WSA, either by resolution of the Council or by any authorised officer of the WSA.
Backflow	The unplanned reversal of flow of water or mixtures of water and contaminants into the water supply system.
Council	The Kawerau District Council or any officer authorised to exercise the authority of the Council.
Customer	A person who uses, or has obtained the right to use or direct the manner of use of, water supplied by the WSA.
Detector check valve	A check (non-return) valve which has a positive closing pressure and a metered bypass to measure flows typically associated with leakage or unauthorised use on a dedicated fire supply.
Extraordinary supply	A category of 'on demand' supply including all purposes for which water is supplied other than ordinary supply and which may be subject to specific conditions and limitations.
Fees and charges	The list of items, terms, and prices for services associated with the supply of water as adopted by the Council in accordance with the LGA 2002 and the Local Government (Rating) Act 2002.
Level of service	The measurable performance standards on which the WSA undertakes to supply water to its customers.
On demand supply	A supply which is available 'on demand' directly from the point of supply subject to the agreed level of service.
Ordinary supply	A category of 'on demand' supply used solely for domestic purposes.
Person	A natural person, corporation sole or a body of persons whether corporate or otherwise.
Point of supply	The point on the water pipe leading from the water main to the premises, which marks the boundary of responsibility between the customer and the WSA, irrespective of property boundaries.
Potable	As defined in section 69G of the Health Act 1956.

Premises	Premises include the following: (a) A property or allotment which is held under a separate certificate of title or for which a separate certificate of title may be issued and in respect to which a building consent has been or may be issued; or (b) A building or part of a building that has been defined as an individual unit by a cross-lease, unit title or company lease and for which a certificate of title is available; or (c) Land held in public ownership (e.g. reserve) for a particular purpose.
Public notice	As defined in the Local Government Act 2002.
Ranger	A person responsible for the management of a WSA controlled catchment area or water reserve.
Restricted flow supply	A type of water supply connection where a small flow is supplied through a flow control device and storage is provided by the customer to cater for the customer's demand fluctuations.
Restrictor	A flow control device fitted to the service pipe to limit the flow rate of water to a customer's premises.
Roading authority	A territorial authority or New Zealand Transport Agency.
Rural water supply area	An area formally designated by a WSA as an area serviced by a reticulated water supply system that is intended to supply water for specified purposes via restricted flow supplies and/or on demand supplies, but not necessarily with a fire-fighting capability.
Service pipe	The section of water pipe between a water main and the point of supply.
Service valve (Toby)	The valve at the customer end of the service pipe.
Storage tank	Any tank having a free water surface.
Supply pipe	The section of pipe between the point of supply and the customer's premises through which water is conveyed to the premises.
Urban water supply area	The area serviced by the on demand reticulated water supply system with a fire-fighting capability.
Water supply authority (WSA)	The operational unit of the Council responsible for the supply of water, including its authorised agents.
Water supply system	All those components of the network between the point of abstraction from the natural environment and the point of supply. This includes, but is not limited to: Wells, infiltration galleries, intake structures, open raw water storage ponds/lakes, falling mains, treatment plants, treated water reservoirs, trunk mains, service mains, rider mains, pump stations and pumps, valves, hydrants, scour lines, service pipes, boundary assemblies, meters, backflow prevention devices and tobies.
Water unit	The basis of measurement for a restricted flow supply and equal to a volume of 365m ³ delivered at the rate of 1m ³ per day.

8 Protection of water supply

8.1 Water supply system

8.1.1 Access to system

No person other than the WSA and its authorised agents shall have access to any part of the water supply system, except to connect to the point of supply, subject to 9.1 and to operate the service valve.

8.1.2 No person to connect to, or interfere with a water supply system

Except as set out in 8.1.1, 8.1.3 and 8.1.4, no person shall make any connection to, or otherwise interfere with, any part of the water supply system.

8.1.3 Fire hydrants

Only the attending Fire Service/s shall gain access to and draw water from fire hydrants for the purpose of fighting fires, training, and testing.

NOTE – Use of the fire hydrants by untrained personnel can result in damage to the water supply system.

8.1.4 Other uses

The right to gain access to and draw water from the water supply for uses other than fire-fighting (for example, flow testing or pipe flushing) shall be restricted to:

- (a) The WSA or its agents.
- (b) Permit holders, being those persons who after having submitted an application to the WSA are subsequently approved to draw water from fire hydrants or tanker filling points. Such permits shall be valid only so long as the permit holder complies with the conditions endorsed on the permit. Without prejudice to other remedies available, the WSA may remove and hold any equipment used by an offender to gain access to, or draw water from a fire hydrant, and assess and recover the value of water drawn without authorisation and any other associated costs.

8.1.5 Working around buried services

The WSA shall keep accurate permanent records ('as-builts') of the location of its buried services. This information shall be available for inspection at no cost to users. Charges may be levied to cover the costs of providing copies of this information.

Any person proposing to carry out excavation work shall view the as-built information to establish whether or not WSA services are located in the vicinity. At least five working days notice in writing shall be given to the WSA of an intention to excavate in the vicinity of its services.

Where appropriate the WSA shall mark out to within ± 0.5 m on the ground the location of its services and nominate in writing any restrictions on the work it considers necessary to protect its services. The WSA may charge for this service.

When excavating and working around buried services due care shall be taken to ensure the services are not damaged and that bedding and backfill are reinstated in accordance with the appropriate WSA specification.

Any damage which occurs to a WSA service shall be reported to the WSA immediately. The person causing the damage shall reimburse the WSA with all costs associated with repairing the damaged service and any other costs the WSA incurs as a result of the incident.

NOTE – Excavation within roadways is also subject to the permit process of the appropriate roading authority.

8.2 Protection of source water

8.2.1 Catchment classes

Surface water and groundwater catchment areas from which untreated water is drawn for the purposes of water supply are designated as open.

8.2.2 Open catchments

Other than any provisions of the regional or district plan and the National Environmental Standard, there are generally no restrictions on activities in open catchment areas.

8.2.3 Spillages and adverse events

In the event of a spillage, or any event which may compromise the water supply, the person responsible for the event shall advise the WSA with due urgency. This requirement shall be in addition to those other notification procedures which are required for other authorities.

9 Conditions of supply

9.1 Application for supply

9.1.1 Initial application

Every application for a supply of water shall be made in writing on an approved WSA form accompanied by the prescribed charges. The applicant shall provide all the details required by the WSA.

On receipt of an application the WSA shall, after consideration of the matters in 9.4 and 9.5, either:

- (a) Approve the application and inform the applicant of the type of supply, the level of service, the size of the connection and any particular conditions applicable; or

- (b) Refuse the application and notify the applicant of the decision giving the reasons for refusal.

For the agreed level of service to the applicant, the WSA should determine the sizes of all pipes, fittings and any other equipment, up to the point of supply. The WSA shall supply and install the service pipe up to the point of supply at the applicant's cost or may allow the supply and installation of the service pipe to be carried out by approved contractors.

The applicant shall have the authority to act on behalf of the owner of the premises for which the supply is sought, and shall produce written evidence of this if required.

An approved application for supply which has not been actioned within six months of the date of application will lapse unless a time extension has been approved. Any refund of fees and charges shall be at the discretion of the WSA.

9.1.2 Change of use

Where a customer seeks a change in the level of service or end use of water supplied to premises and/or the supply changes from an ordinary to an extraordinary type (see 9.4) or vice versa, a new application for supply shall be submitted by the customer.

9.1.3 Prescribed charges

Charges applicable at the time of connection may include:

- (a) Payment to the WSA for the cost of the physical works required to provide the connection.
- (b) A development contribution charge determined in accordance with the Local Government Act 2002.
- (c) A financial contribution charge determined in accordance with the Resource Management Act 1991.

9.2 Point of supply

9.2.1 Responsibility for maintenance

The WSA shall own and maintain the service pipe and fittings up to the point of supply.

The customer shall own and maintain the supply pipe beyond the point of supply.

9.2.2 Single ownership

For individual customers the point of supply shall be located as shown in figure 1 or as close as possible where fences, walls, or other permanent structures make it difficult to locate it at the required position. Other positions shall require specific approval.

For each individual customer there shall be only one point of supply, unless otherwise approved.

The typical layout at a point of supply is shown in figure 2.

The WSA gives no guarantee of the serviceability of the valve located on the service pipe. Where there is no customer stopcock, or where maintenance is required between the service valve and the customer stopcock, the customer may use the service valve to isolate the supply. However, the WSA reserves the right to charge for maintenance of this valve if damaged by such customer use.

Figure 1 – Point of supply location – Individual customers

NOTE: Point of supply is a tail piece of boundary box, meter or service valve regardless of property boundary.

Example 1 – With street frontage

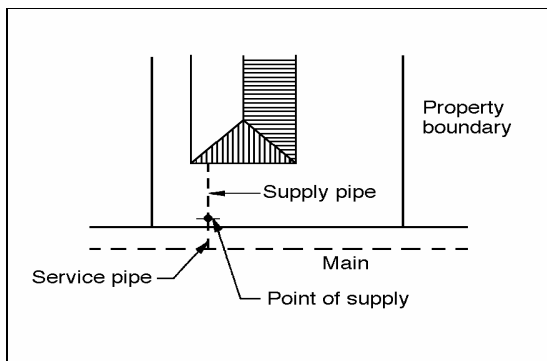

Type 1: Point of supply inside property boundary

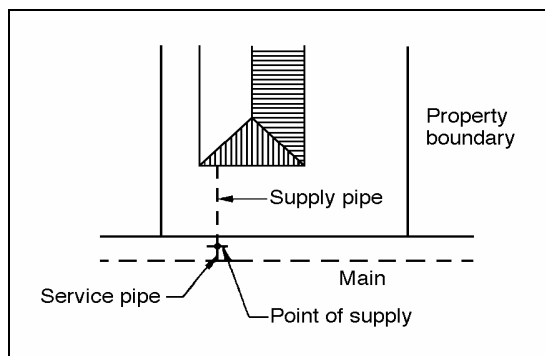

Type 2: Point of supply outside property boundary

Example 2 – Rear lots on right of way

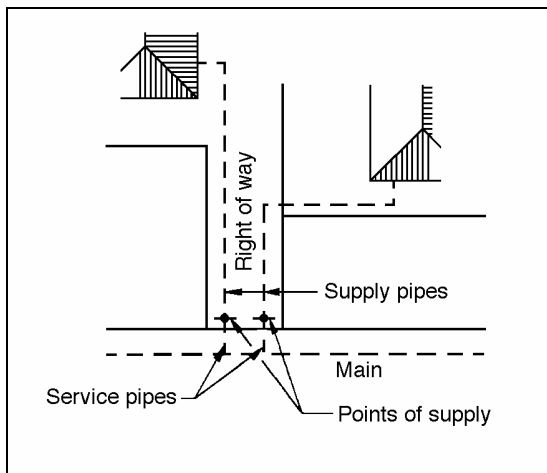

Type 1: Point of supply inside property boundary

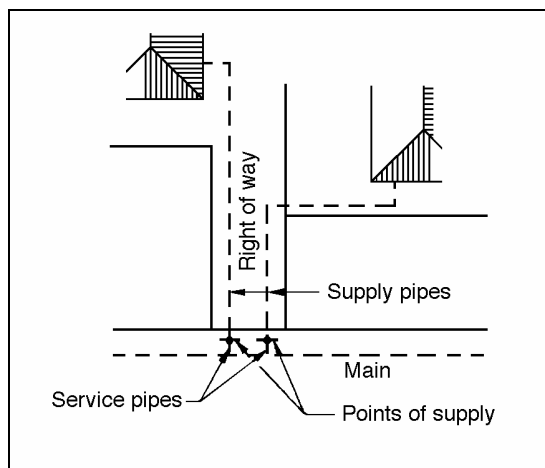

Type 2: Point of supply outside property boundary

Example 3 – Industrial, commercial, domestic fire and service connections (including schools)

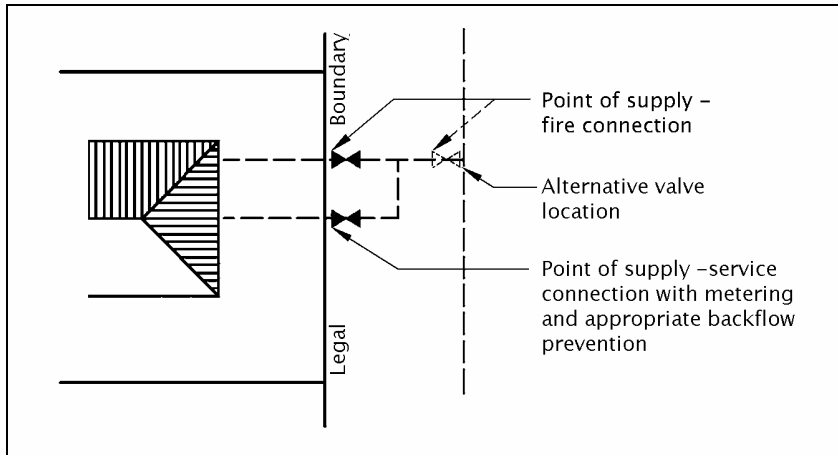

Type 1: Combined fire and service connection

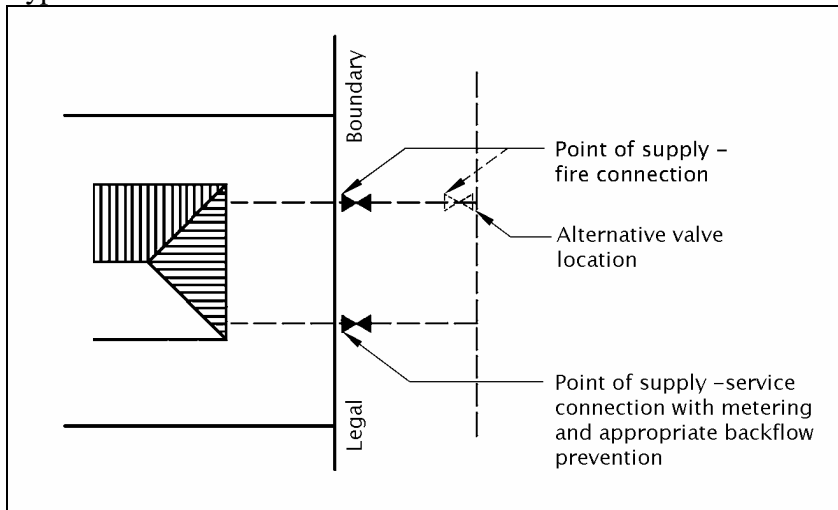

Type 2: Separate fire and service connection

Figure 2 – Typical layout at point of supply

NOTE: Point of supply is tail piece of boundary box, meter or service valve regardless of property boundary

Example 4 – Domestic unmetered supply

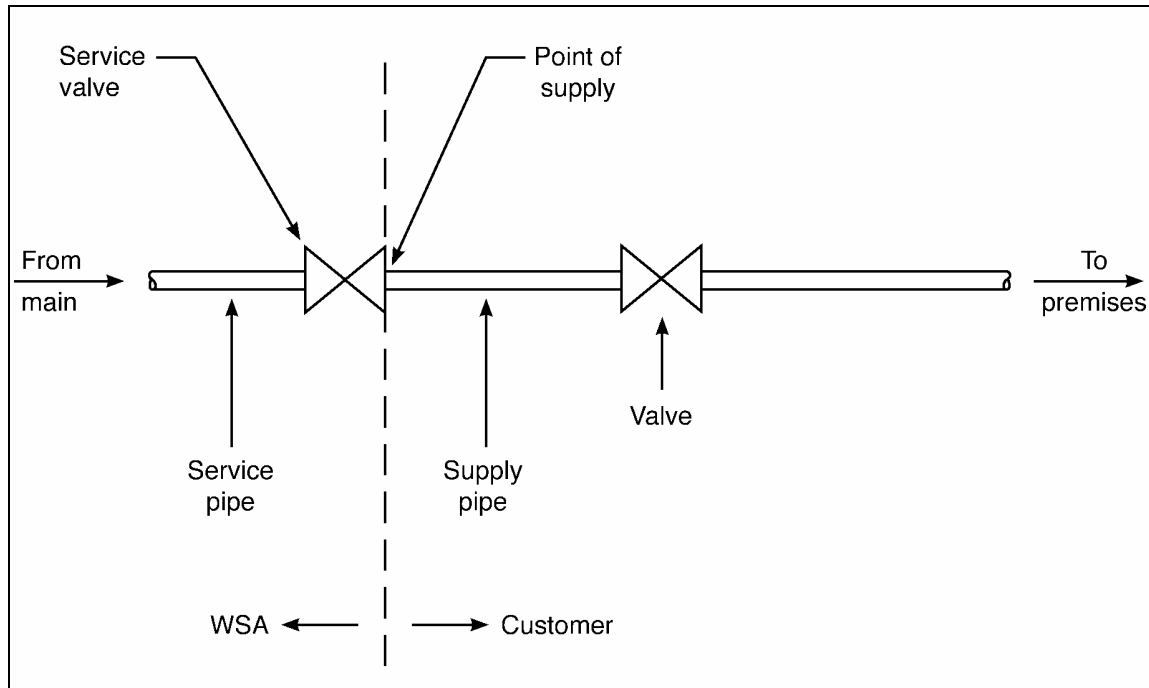

Example 5 – Domestic metered supply

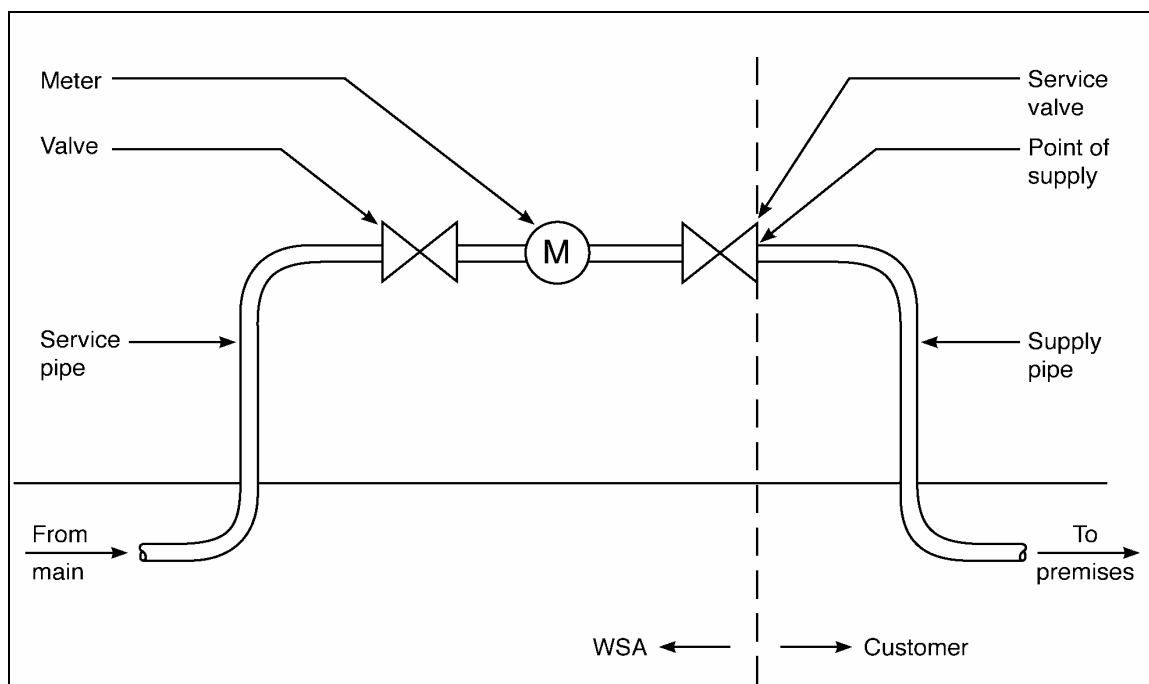

Example 6 – Metered supply with backflow prevention device owned by WSA

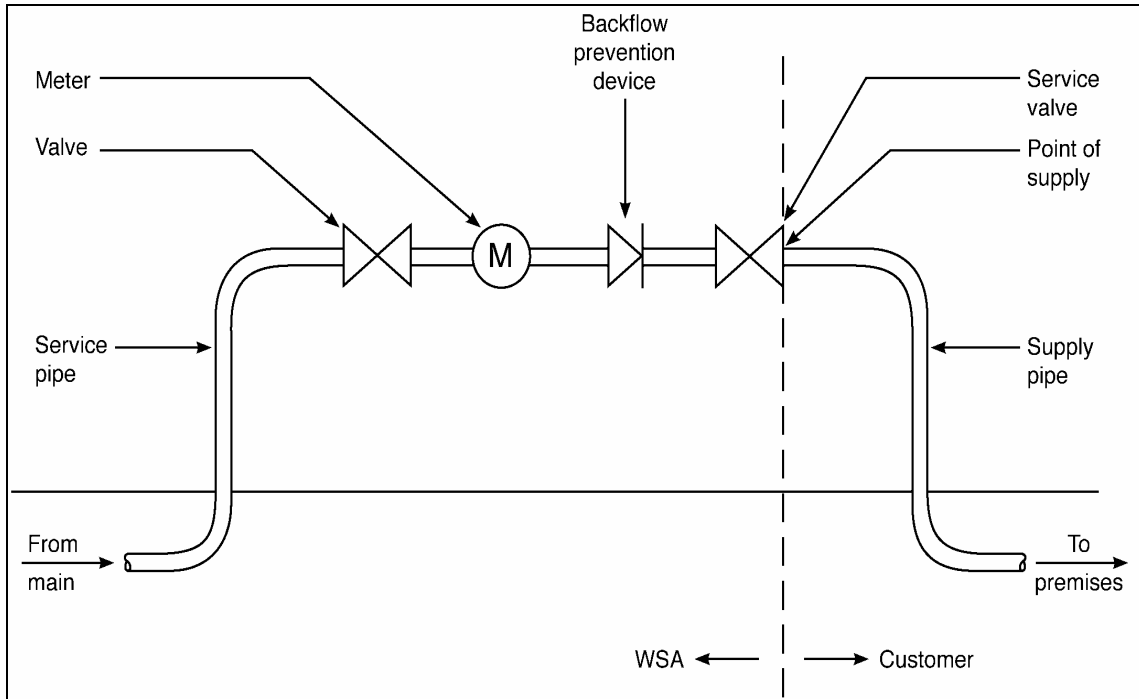

Example 7 – Unmetered supply with backflow prevention device owned by WSA

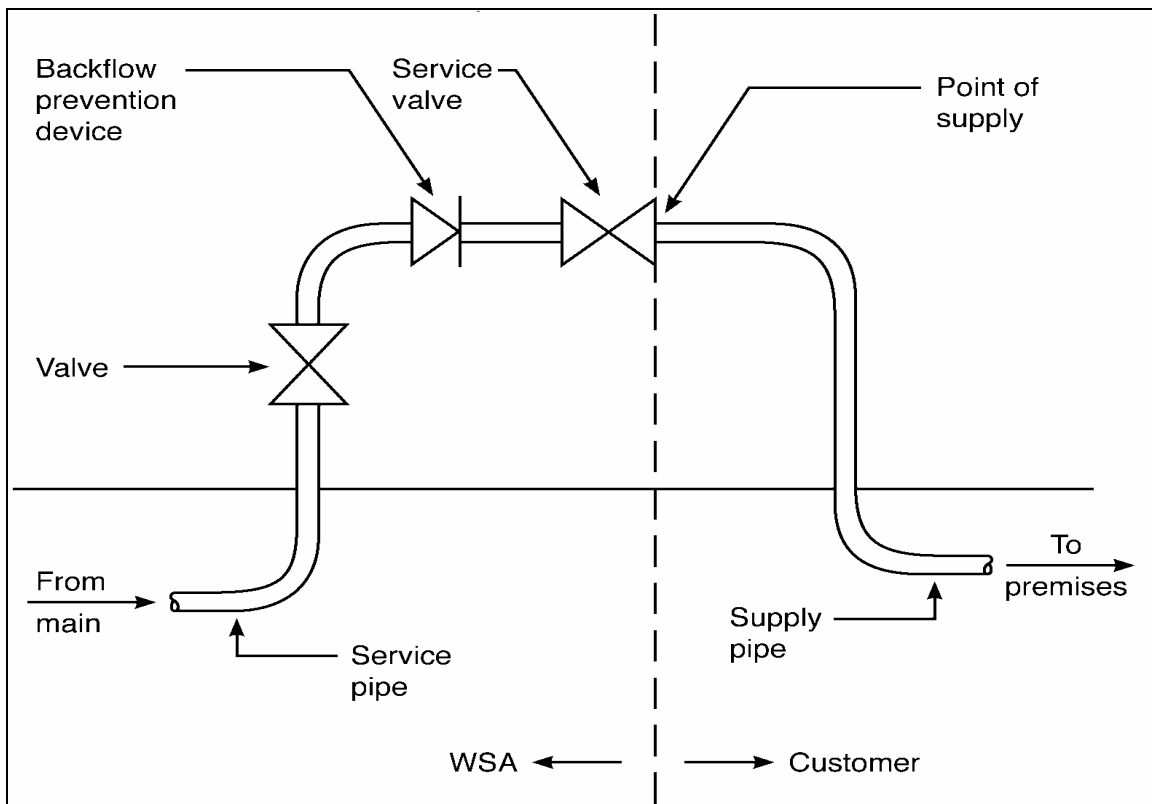

Example 8 – Unmetered supply with backflow prevention device owned by the customer

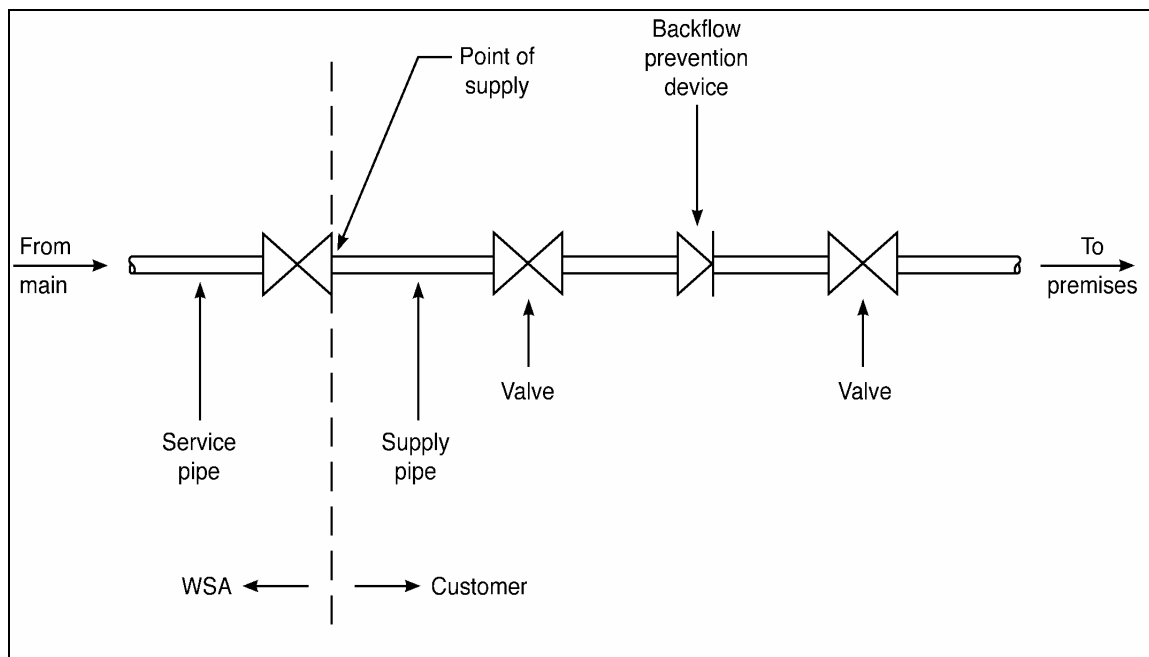

9.2.3 Multiple ownership

The point of supply for the different forms of multiple ownership of premises and/or land shall be:

- (a) For Company Share/Block Scheme (Body Corporate) – as for single ownership.
- (b) For Leasehold/Tenancy in Common Scheme (Cross Lease), Strata Title, Unit Title (Body Corporate) and any other form of multiple ownership – each customer shall have an individual supply with the point of supply determined by agreement with the WSA. In specific cases other arrangements may be acceptable, subject to individual approval.

For a multiple ownership supply which was in existence prior to the coming into effect of this Bylaw, the point of supply shall be the arrangement existing at that time, or as determined by agreement with the WSA for any individual case.

9.3 Access to and about point of supply

9.3.1 Rights of access

Where the point of supply is on private property the customer shall allow the WSA access to and about the point of supply between 7.30 am and 6 pm on any day for:

- (a) Meter reading without notice; or
- (b) Checking, testing and maintenance work with notice being given whenever possible.

Outside these hours (such as for night time leak detection) the WSA shall give notice to the customer. Where access is not made available for any of the above times and a return visit is required by the WSA, a rate may be charged as for 'Meter reading by appointment'. Under emergency conditions the customer shall allow the WSA free access to and about the point of supply at any hour.

9.3.2 Maintenance of access

The customer shall maintain the area in and around the point of supply keeping it free of soil, growth, or other matter or obstruction which prevents, or is likely to prevent convenient access.

9.4 Types of supply

9.4.1 General

Supplies shall be classified as either 'on demand' or 'restricted flow' and the use of water from the supply shall be either 'ordinary' or 'extraordinary'.

9.4.2 On demand supply

Every premise shall be entitled to an ordinary supply of water subject to the following conditions:

- (a) The premises lying within the Kawerau District water supply area if such an area has been constituted by the WSA.
- (b) The exclusion of its use for garden watering under any restrictions made by the WSA under 9.7.3.
- (c) Payment of the appropriate charges in respect of that property.
- (d) Any other charges or costs associated with subdivisional development; and
- (e) Any other relevant conditions in section 9 of this Bylaw.

The WSA shall be under no obligation to provide an extraordinary supply of water (see also the provisions of 9.7 and 9.9.2).

9.4.3 Restricted flow supply

Restricted flow supply shall be available to premises within a designated area only, or under special conditions set by the WSA. The water supply shall be restricted so as to deliver the agreed number of water units at a steady flow rate.

The WSA shall charge for the restricted flow supply by either:

- (a) The volume passing through a meter; or
- (b) The agreed number of water units.

9.4.4 Ordinary use

Ordinary use is for domestic purposes (which may include use in a fire sprinkler system to NZS4517) and shall include:

- (a) Washing down a car, boat, fixed structure or similar.
- (b) Garden watering by hand.
- (c) Garden watering by a portable sprinkler (subject to the provisions of 9.7.3).

NOTE – For use from a fire protection system to NZS 4517 to be classified as an ordinary use, the customer should comply with the conditions set under 9.9.1.

9.4.5 Extraordinary use

Extraordinary use includes:

- (a) Domestic – spa or swimming pool in excess of 10 m³ capacity and fixed garden irrigation systems.
- (b) Commercial and business.
- (c) Industrial.
- (d) Agricultural.
- (e) Horticultural.
- (f) Viticultural.
- (g) Lifestyle blocks (peri-urban or small rural residential).
- (h) Fire protection systems other than sprinkler systems installed to comply with NZS 4517.
- (i) Out of district (supply to, or within another local authority).
- (j) Temporary supply.

9.5 Metering

An ordinary use of water shall not normally be metered (subject to the WSA reserving the right to fit a meter and charge where it considers water use is excessive, or for a meter to be fitted at the customer's request) and the cost of such use shall be as prescribed in the Local Government (Rating) Act 2002, sections 9, 15 to 19 and sections 101 to 103.

An extraordinary use shall normally be metered and charged for in accordance with 9.15. Where the extraordinary use is for fire protection only, this supply shall not normally be metered.

9.6 Level of service

The WSA shall provide water in accordance with the level of service contained in the Long Term Council Community Plan. For those periods where the level of service allows non-compliance with the specified value(s), the WSA should make every reasonable attempt to achieve the specified value(s).

9.7 Continuity of supply

9.7.1 Supply

Due to practical and physical limitations, the WSA cannot guarantee an uninterrupted or constant supply of water in all circumstances, or the continuous maintenance of any particular pressure, but shall do its best to meet the continuity of supply levels of 9.6, subject to the exemptions contained in 9.7.3 and 9.7.4.

Where works of a permanent or temporary nature are planned which will affect an existing supply, the WSA shall consult with, or inform or give notice to all known customers likely to be substantially affected.

9.7.2 Uninterrupted service

If a customer has a particular requirement for an uninterrupted level of service (flow, pressure, or quality), it shall be the responsibility of that customer to provide any storage, back-up facilities, or equipment necessary to provide that level of service.

9.7.3 Demand management

The customer shall comply with any restrictions which may be approved by the WSA to manage high seasonal or other demands. Such restrictions shall be advised by public notice.

Even when such restrictions apply, the WSA shall take all practicable steps to ensure that an adequate supply for domestic purposes is provided to each point of supply.

9.7.4 Emergency restrictions

During an emergency, the WSA may restrict or prohibit the use of water for any specified purpose, for any specified period and for any or all of its customers. Such restrictions shall be advised by public notice. The WSA may enact penalties over and above those contained in these conditions to enforce these restrictions. The decision to make and lift restrictions and to enact additional penalties, shall be made by the Council, or where immediate action is required, by the manager of the WSA, subject to subsequent Council ratification.

9.7.5 Maintenance and repair

Wherever practical, the WSA shall make every reasonable attempt to notify the customer of a scheduled maintenance shutdown of the supply before the work commences. Where immediate action is required and notification is not practical, the WSA may shut down the supply without notice.

9.8 Liability

The WSA shall endeavour to meet the level of service requirements of 9.6, but shall not be liable for any loss, damage or inconvenience which the customer (or any person using the supply) may sustain as a result of deficiencies in, or interruptions to, the water supply.

The WSA may, under certain circumstances and at its sole discretion, make payments for damage caused to equipment, appliances, processes and materials as a direct result of a variation in the water supply, provided that any such equipment or appliances have been designed to cater for reasonable variations in the flow, pressure and quality of the water supply.

9.9 Fire protection connection

9.9.1 Connection application

Any proposed connection for fire protection shall be the subject of a specific application (on an approved WSA form) made to the WSA for approval. Any such connection shall be subject to the conditions specified by the WSA.

9.9.2 Design

It shall be the customer's responsibility to ascertain in discussion with the WSA and monitor whether the supply available is adequate for the intended purpose.

9.9.3 Fire protection connection metering

Where the supply of water to any premises is metered, the WSA may allow the supply of water for the purposes of fire-fighting to be made in a manner which bypasses the meter, provided that:

- (a) The drawing of water is possible only in connection with the sounding of an automatic fire alarm or the automatic notification of the fire brigade; or
- (b) A WSA approved detector check valve has been fitted on the meter bypass.

Any unmetered connection provided to supply water to a fire protection system shall not be used for any purpose other than fire-fighting and testing the fire protection system unless the fire protection system is installed in accordance with NZS 4517.

Where a fire connection has been installed or located so that it is likely or possible that water may be drawn from it by any person for purposes other than fire-fighting, the WSA may require the supply to be metered.

9.9.4 Fire hose reels

Where the supply of water to any premises is metered, fire hose reels shall be connected only to the metered supply, not to the fire protection system. The water supply to fire hose reels shall comply with the requirements of NZS 4503.

9.9.5 Charges

Water used for the purpose of extinguishing fires shall be supplied free of charge. Where the fire protection connection is metered and water has been used for fire-fighting purposes, the WSA shall estimate the quantity of water so used and credit to the customer's account an amount based on such an estimate.

9.9.6 Ongoing testing and monitoring

Customers intending to test fire protection systems in a manner that requires a draw-off of water, shall obtain the approval of the WSA beforehand. Water used for routine flushing and flow testing does not constitute waste, but the quantity of water used may be assessed and charged for by the WSA.

9.10 Backflow prevention

9.10.1 Customer responsibility

It is the customer's responsibility (under the Health Act 1956, and the Building Act 2004) to take all necessary measures on the customer's side of the point of supply to prevent water which has been drawn from the WSA's water supply from returning to that supply.

These include:

- (a) Backflow prevention either by providing an adequate air gap, or by the use of an appropriate backflow prevention device.
- (b) The prohibition of any cross-connection between the WSA water supply and
 - (i) Any other water supply (potable or non-potable).
 - (ii) Any other water source.
 - (iii) Any storage tank.
 - (iv) Any other pipe, fixture or equipment containing chemicals, liquids, gases, or other non-potable substances.

NOTE – Fire protection systems that include appropriate backflow prevention measures would generally not require additional backflow prevention, except in cases where the system is supplied by a non-potable source or a storage tank or fire pump that operates at a pressure in excess of the WSA's normal minimum operating pressure.

9.10.2 Unmanaged risk

Notwithstanding 9.10.1 the WSA may fit a backflow prevention device on the WSA side of the point of supply where the customer cannot demonstrate that the risk of backflow is adequately managed.

9.11 WSA equipment and inspection

9.11.1 Care of water supply system

The customer shall take due care not to damage any part of the water supply system, including, but not limited to pipework, valves, meters, restrictors, chambers and backflow prevention devices.

9.11.2 Inspection

Subject to the provisions of the Local Government Act 2002, the customer shall allow the WSA with or without equipment, access to any area of the premises for the purposes of determining compliance with these conditions.

9.12 Meters and flow restrictors

9.12.1 Installation

Meters for on demand supplies and restrictors for restricted flow supplies, shall be supplied, installed and maintained by the WSA and shall remain the property of the WSA. Where on demand supplies are not universally metered, the WSA, where it considers water use is unusually high, reserves the right to fit a meter at the customer's cost and charge accordingly.

9.12.2 Location

Meters and restrictors shall be located in a position where they are readily accessible for reading and maintenance and if practicable immediately on the WSA side of the point of supply, (see figure 2).

9.12.3 Accuracy

Meters shall be tested as and when required by the WSA or as prescribed in OIML R49. The maximum permissible error for the upper flow rate zone ($Q_2 < Q < Q_4$) is $\pm 2\%$, for temperatures from 0.3°C to 30°C and the maximum permissible error for the lower flow rate zone ($Q_1 < Q < Q_2$) is $\pm 5\%$. This accuracy shall be applied to all water meters with $Q_3 < 100 \text{ m}^3/\text{h}$ and may be applied to water meters with values of $Q_3 > 100 \text{ m}^3/\text{h}$.

The flow restrictors shall be accurate to within $\pm 10\%$ of their rated capacity.

NOTE – Where Q is the flow rate:

Q1 is the minimum flow rate.

Q2 is the transitional flow rate.

Q3 is the permanent flow rate; and

Q4 is the overload flow rate as defined in OIML R49-1.

Any customer who disputes the accuracy of a meter or restrictor may apply to the WSA for it to be tested provided that it is not within three months of the last test.

If the test shows non-compliance with the accuracy above, the customer shall not be charged for the test. If the test shows compliance, the customer shall pay a fee in accordance with the WSA current fees and charges.

Meters shall be tested as prescribed in OIML R 49-2 and the test report shall be made available as prescribed in OIML R 49-3.

The variation in the error curve shall not exceed 3% for flow rates in the lower zone and 1.5% for flow rates in the upper zone. For the purpose of determining these requirements the mean values of the errors (of indication) at each flow rate, shall apply.

The curves shall not exceed a maximum error of $\pm 6\%$ for flow rates in the lower zones and $\pm 2.5\%$ for flow rates in the upper zones.

Restrictors shall be tested by measuring the quantity that flows through the restrictor in a period of not less than one hour at the expected minimum operating pressure. A copy of independent certification of the test result shall be made available to the customer on request.

9.12.4 Adjustment

If any meter, after being tested, is found to register a greater or lesser consumption than the quantity of water actually passed through such a meter, the WSA shall make an adjustment in accordance with the results shown by such tests, backdated for a period at the discretion of the WSA, but not exceeding 12 months and the customer shall pay a greater or lesser amount according to the adjustment.

Where a meter is under-reading by more than 20% or has stopped, the WSA reserves the right to charge for the amount of water assessed as having been used over the past billing period, taking into account any seasonal variations in demand.

Where a meter is over-reading, the WSA shall make appropriate adjustments to the customer's invoice(s), based on a period of similar use and backdated to when it is agreed the over-reading is likely to have occurred.

9.12.5 Estimating consumption

Should any meter be out of repair or cease to register, or be removed, the WSA shall estimate the consumption for the period since the previous reading of such meter, (based on the average of the previous four billing periods charged to the customer) and the customer shall pay according to such an estimate. Provided that when by reason of a large variation of consumption due to seasonal or other causes, the average of the previous four billing periods would be an unreasonable estimate of the consumption, the WSA may take into consideration other evidence for the purpose of arriving at a reasonable estimate and the customer shall pay according to such an estimate.

If metering shows a significant increase in consumption for a premises and the increase is established as being caused by a previously unknown leak, the WSA may estimate consumption as above, providing that the customer repairs the leak with due diligence.

Where the seal or dial of a meter is broken, the WSA may declare the reading void and estimate consumption as described above.

9.12.6 Incorrect accounts

Where a situation occurs, other than as provided for in 9.12.5, where the recorded consumption does not accurately represent the actual consumption on a property, the account shall be adjusted using the best information available to the WSA. Such situations include, but are not limited to, misreading of the meter, errors in data processing, meters assigned to the wrong account and unauthorised supplies.

Where an adjustment is required, in favour of the WSA or the customer, this shall not be backdated more than 12 months from the date the error was detected.

9.13 Plumbing system

Quick-closing valves, pumps, or any other equipment which may cause pressure surges or fluctuations to be transmitted within the water supply system, or compromise the ability of the WSA to maintain its stated levels of service shall not be used on any piping beyond the point of supply. In special circumstances such equipment may be approved by the WSA.

In accordance with the Building Regulations 1992 the plumbing system shall be compatible with the water supply. Specific features of the WSA supply which need to be taken into account are contained in table 1.

Table 1 – Compatibility features

Feature	Value		
	PSI	Metres	kPa
Maximum pressure	80	56	551
Minimum pressure	40	28	275
Normal operating pressure	70	49	482

9.14 Prevention of waste

The customer shall not intentionally allow water to run to waste from any pipe, tap, or other fitting, nor allow the condition of the plumbing within the property to deteriorate to the point where leakage or wastage occurs.

The WSA provides water for consumptive use not as an energy source. The customer shall not use water or water pressure directly from the supply for driving lifts, machinery, eductors, generators, or any other similar device, unless specifically approved.

The customer shall not use water for a single pass cooling system or to dilute trade waste prior to disposal, unless specifically approved.

9.15 Payment

The customer shall be liable to pay for the supply of water and related services in accordance with the WSA fees and charges prevailing at the time.

The WSA may recover all unpaid water charges as prescribed in the Local Government (Rating) Act 2002, sections 57 to 82.

9.16 Transfer of rights and responsibilities

The customer shall not transfer to any other party the rights and responsibilities set out in this Bylaw.

A supply pipe shall serve only one customer and shall not extend by hose or any other pipe beyond that customer's property.

In particular, and not in limitation of the above, any water which the customer draws from the WSA supply shall not be provided to any other party without approval of the WSA.

9.17 Change of ownership

In the event of a premise changing ownership, the WSA shall record the new owner as being the customer at that premise. Where a premise is metered, the outgoing customer shall give the WSA five working days' notice to arrange a final meter reading.

9.18 Disconnection at the customer's request

The customer shall give 20 working days' notice in writing to the WSA of the requirement for disconnection of the supply. Disconnection shall be at the customer's cost.

10 Offences and Breaches

10.1 Breaches of conditions of supply

The following are deemed breaches of the conditions to supply water:

- (a) An incorrect application for supply which fundamentally affects the conditions of supply (section 9)
- (b) Failure by the customer to meet and comply with the conditions of supply
- (c) Failure to meet any obligation placed on the customer under all current Acts and Regulations specified in section 5(a)
- (d) Frustration of the WSA's ability to adequately and effectively carry out its obligations
- (e) An act or omission including, but not limited to any of the following:
 - (i) Failure to pay the appropriate charges by the due date.

- (ii) Failure to repair a leak, or in any way wilfully allowing water to run to waste, or to be misused.
- (iii) The fitting of quick-closing valves, pumps, or any other equipment which may cause pressure surges or fluctuations to be transmitted within the water supply system, or compromise the ability of the WSA to maintain its stated levels of service (subject to 9.13).
- (iv) Failure to prevent backflow (see 9.10).
- (v) Failure to comply with water use restrictions or prohibitions introduced by the WSA for any specified purpose.
- (vi) Using water or water pressure directly from the supply for driving lifts, machinery, educators, generators, or any other similar device, unless specifically approved by the WSA.
- (vii) Using water for a single pass cooling or heating system, or to dilute trade waste prior to disposal, unless specifically approved.
- (viii) Extending by hose or any other pipe a private water supply beyond that customer's property.
- (ix) Providing water drawn from the WSA supply to any other party without approval of the WSA.

In the event of a breach, the WSA shall serve notice on the customer advising the nature of the breach and the steps to be taken to remedy it. If, after one week, the customer persists in the breach, the WSA reserves the right to reduce the flow rate of water to the customer without notice. In such an event, the full service of the supply shall be re-established only after payment of the appropriate fee and remedy of the breach to the satisfaction of the WSA.

In addition, if the breach is such that the WSA is required to disconnect the supply for health or safety considerations, such disconnection should be carried out forthwith.

10.2 Interference with equipment

Any tampering or interfering with WSA equipment, either directly or indirectly, shall constitute a breach. Without prejudice to its other rights and remedies, the WSA shall be entitled to estimate (in accordance with 9.12.5) and charge for the additional water consumption not recorded or allowed to pass where a meter or restrictor has been tampered with and recover any costs incurred.

10.3 Penalties

- a) Subject to anything to the contrary, every person who commits an offence against this Bylaw shall be subject to the penalties set out in section 242(4) of the Local Government Act 2002.

- b) Under section 163 of the Local Government Act 2002, the WSA or an authorised agent appointed by it, may remove or alter any work or thing that is, or has been constructed in breach of this Bylaw.
- c) The Council may recover the costs of removing or altering the work or thing that is in breach of this Bylaw from the person who committed the breach. This does not relieve that person of liability for the breach.
- d) Under section 162 of the Local Government Act 2002, the WSA may apply to the District Court for the grant of an injunction restraining a person from committing a breach of this Bylaw.
- e) The WSA may seize and impound property materially involved in the commission of an offence, under and in accordance with sections 164 and 165 of the Local Government Act 2002.
- f) The WSA will return or dispose of property seized and impounded in accordance with sections 167 and 168 of the Local Government Act 2002.

Revocations

The Kawerau District Council Water Supply Bylaw 1958 is hereby revoked.

The Kawerau District Council Water Supply Bylaw 2009 was duly made by a resolution passed at a meeting of the Kawerau District Council held on 28 April 2009, following a special consultative procedure.

The Common Seal of the
Kawerau District Council
 was affixed hereto in the presence of:

.....
 Mayor

.....
 Chief Executive Officer

.....
 Date